

TELESCOPIC ARM

MADE IN
cosben



cosben[®]
EQUIPMENT CONSTRUCTION
www.cosben-it.com

PRODUCTIVITY

Excavators equipped with “TA” Telescopic Arm are designed to increase productivity on complex demanding excavation projects. They can be used to remove soil from depths of up to 42 meters underground, and load trucks to quickly transport material off-site. You can rely on the range of excavators to operate on the job site smoothly and safely to meet tight deadlines.

CLAMSHELL TELESCOPIC ARM

Using a technologically advanced combination of wire ropes and hydraulic cylinders, the telescopic boom extends and smoothly retracts under full load in seconds. The hydraulic circuit for the excavator range, offer even higher levels of productivity. They have proven to be faster than traditional skip and the crane method of underground excavations, for example. The new models can also be equipped with an optional Shuttle Q-Fit, which provides greater versatility on busy construction sites.

WIRE ROPES SYSTEM

One of several safety features incorporated into the design of the excavator range of telescopic arm excavators is the wire ropes system. This means that, in the unlikely event that one rope should break, the other will hold the telescopic arm firmly in place, until it can be repaired. This is one of the many ways in which the excavator contributes to the safe and successful operation of any job site.

INCORPORATED COUNTERWEIGHT

Another beneficial feature of the excavator range of telescopic excavators is the availability of an additional counterweight. This is incorporated between the machine and the original counterweight, and not changing the appearance of the excavator. Therefore, it allows the machine to be used for a variety of operations on the job site, enhancing its versatility and overall levels of productivity.

SAFETY VALVE

The telescopic arm is also equipped with a safety valve, which, in the unlikely event of a damaged cylinder, will prevent any other impact on the machine or the environment.



HIGH LEVELS OF EFFICIENCY

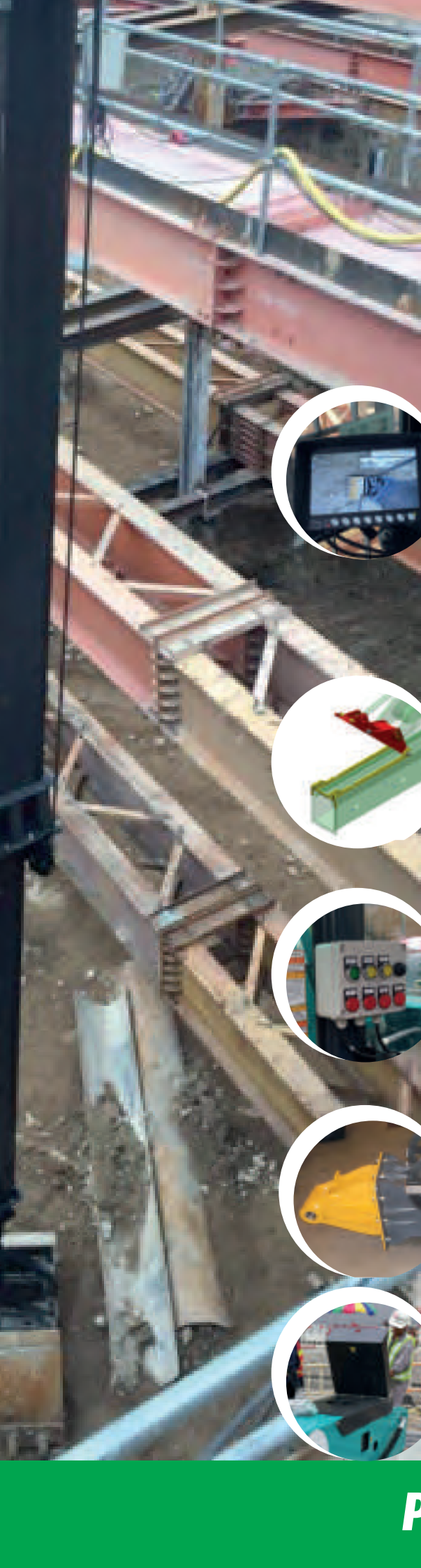

The reliable and efficient operation of your excavator can have a strong impact on the success of your business. Taking this into account, Cosben engineers have designed the clamshell telescopic models with several performance-enhancing features. Our ultimate aim is to produce machines that will enable you to complete underground construction projects safely and on schedule. We believe the performance of the excavator range of clamshell telescopic excavators will extend beyond your expectations, providing you with a quick return on your investment.

VISION SOLUTION CAMERA, ADVANTAGES:

The excavator equipped with telescopic arm it's an example of complex machine where good vision is essential to allow the work to progress smoothly, as Cosben's vision solution allows the safety condition working and improves operating efficiency in the job-site. The operator must often move into unnatural positions to be able to follow what is going on, and this can lead to injury, or forced to stop working. Cosben's vision solution enables the driver to maintain a correct posture and allows him to work in more comfort, offering a dual benefit!

SHUTTLE Q-FIT "QUICK COUPLING"

The TA excavator can also be fitted with an optional Shuttle Q-Fit "quick coupling", which provides greater versatility on busy job sites. Easy to connect and disconnect the Shuttle Q-Fit significantly reduces the time for disassembly / assembly of the clamshell telescopic arm to the excavator, containing substantially the additional costs in transport of excavator.

WARNING SAFETY ALARMS

The safe performance of the excavator with the telescopic arm is aided by the use of warning lights and safety alarms. For example, if one of the two ropes suddenly breaks or goes too far, an indicator light and a warning buzzer will alert the operator immediately. In addition, a warning buzzer will alert the operator if too much pressure is applied once the clamshell bucket has reached the ground and is digging material.

FRONT HEAD'S LINK

When the operator needs to work with two pins on mounting as dredge pump working for example, they need to buy the Front head's link, with the inside head cylinder and link allows to use the two pins fixing.

TOP COVER IN TWO OPENINGS

The easy maintenance features of the excavators contribute to maximum uptime, allowing operators to carry out routine checks quickly, then focus on the main task at hand. One example is the top cover in two openings of the telescopic arm, which can be opened easily for inspection.

PERFORMANCE

WORKING RANGES

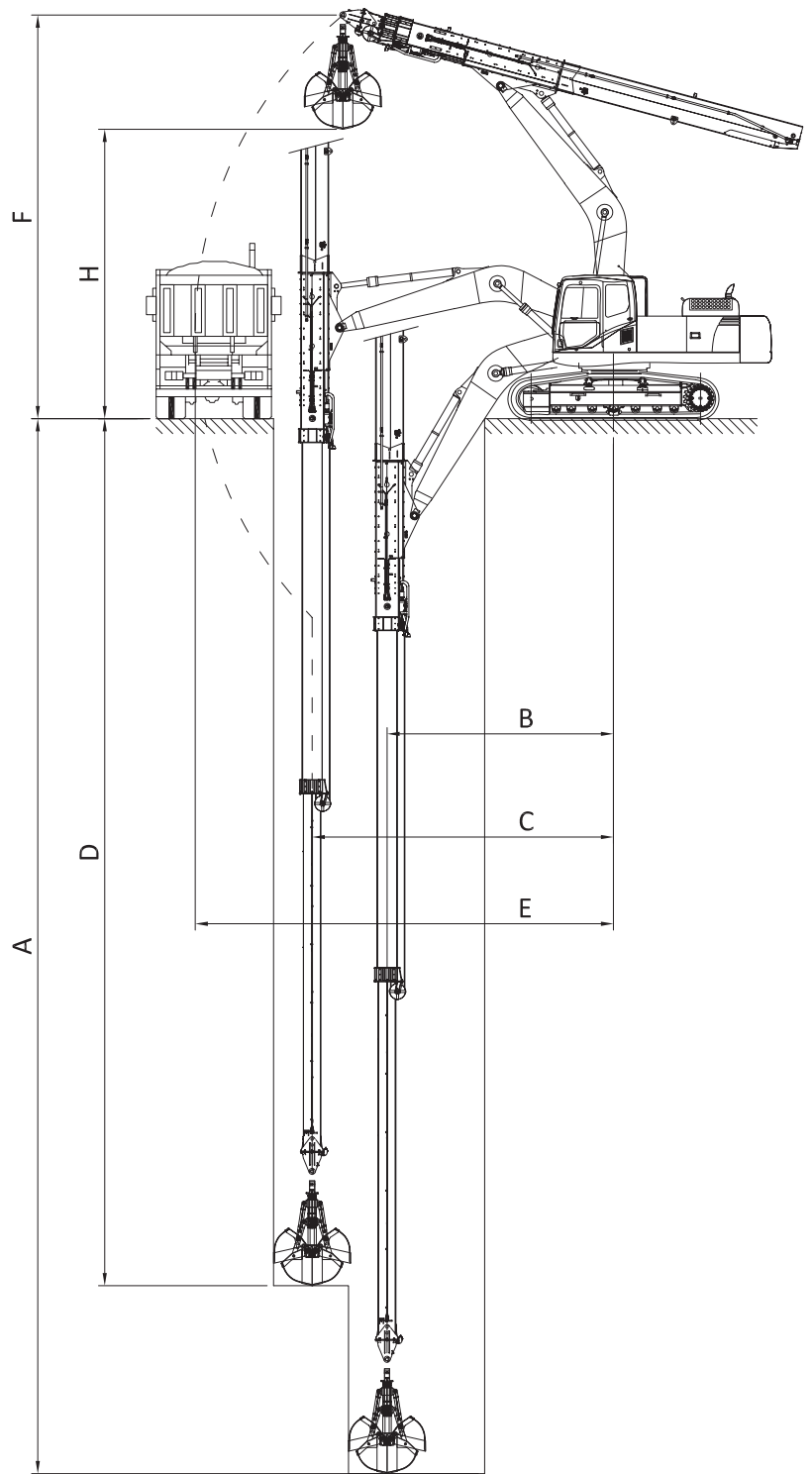

* Speed time with double hydr. Pump
 ** Calculation based for handling material with max. density 1,8T/cu.m

The telescopic arm cylinder work with additional hydraulic line of the excavator. If the end attachments requires some hydraulics line supply for working, the excavator must be equipped on additional hydraulic lines.

Code	A m	B m	C m	D m	E m	F m	H m	Model	Exc. Weight Ton	Note	Speed in second		Clamshell Bucket Code/Cap.ty	** Productivity Ton/Hours From/To
											* Down	Up		
14421TA	18	5	6	10	9	11	8	TA1725	20 - 25	The Excavator must have additional counter weight	11	11	14296CS - 1000 Lt	150 / 200
3021TA	23	5	6	16	9	11	8	TA2325			16	16	14296CS - 800 Lt	120 / 150
12605TA	25	5	7	18	10	11	8	TA2538	26 - 32		16	16	14297CS - 1000 Lt	120 / 150
14415TA	19	6	8	13	10	11	8	TA60FT	33 - 38		8	8	14380CS - 2000 Lt	370 / 510
12605TA	25	6	8	19	10	11	8	TA2538			13	13	14299CS - 1500 Lt	200 / 260
5120TA	30	6	8	22	10	11	8	TA3038			23	15	14298CS - 1300 Lt	140 / 170
13752TA	27	7	9	21	11	12	9	TA2750	39 - 50		10	10	14380CS - 2000 Lt	310 / 410
14155TA	32	7	9	24	11	12	9	TA3250			19	12	14299CS - 1500 Lt	190 / 240
14169TA	35	7	9	28	11	12	9	TA3550			21	13		180 / 220

SHIPPING DIMENSIONS

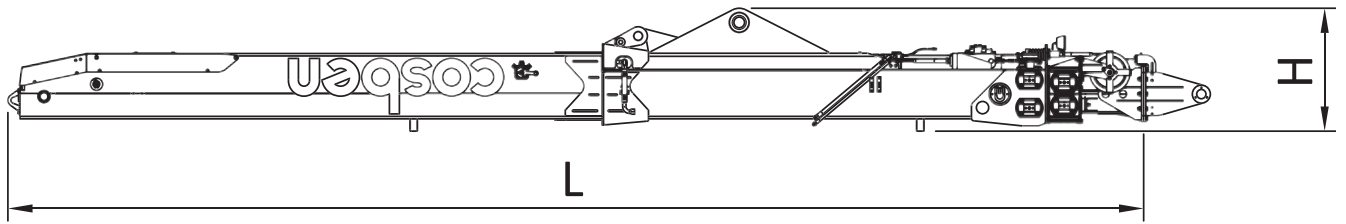

Code	Lenght mm	Height mm	Width mm	Weight Kg	Container
14421TA	8100	1000	730	2900	40'
3021TA	10300	1000	730	3600	
14415TA	7500	1300	740	3750	
12605TA	11500	1300	740	5500	
5120TA	13400	1300	740	6500	45'
13752TA	11500	1400	770	6000	
14155TA	13400	1400	770	7000	
14169TA	14500	1400	770	7500	Flat Rack

* without front head

DIMENSIONS

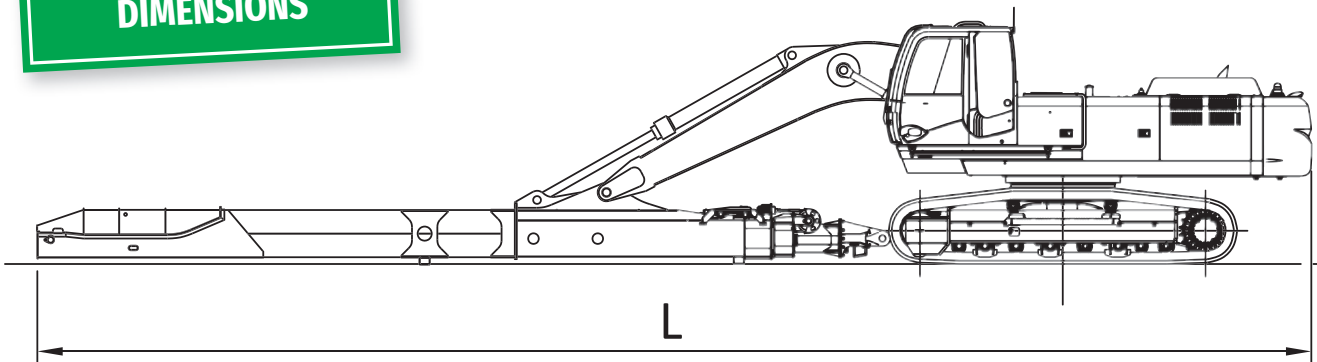

Code	Lenght mm	Height mm
14421TA	13.5	20 - 25
3021TA	15	20 - 25
12605TA	16	25 - 32
14415TA	13	33 - 38
12605TA	17	
5120TA	18	
13752TA	18	39 - 50
14155TA	19	
14169TA	20	



TELESCOPIC ARM



N.B. All data and descriptions are given for information purposes only and they are not binding the manufacturers for any future alteration as they may deem necessary for quality improvement of the attachments.



Via Carrate, 1/D
41030 SOLARA (MO) - ITALY
Phone +39 059 801056
Fax +39 059 801060
info@cosben-it.com

www.cosben-it.com

